



Project: _____

Location: _____

Fixture Type: _____

Catalog Number: _____

AVAILABLE FINISHES:

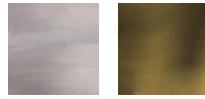

Parel

FM-50437

PRODUCT DESCRIPTION

Spanish Alabaster beads are strung on an LED loop and draped over gleaming arms. Dress up your ceiling with this delightful luminaire.

FEATURES

- Driver concealed within the canopy
- Sculptural frame illuminated by a fixed silica strand of Spanish alabaster orbs
- Premium natural Spanish alabaster stone features unique veining and color variation
- NEC CODE (314.24) requires that ceiling outlet boxes in the U.S. support up to 50 lbs
- This fixture exceeds 50 lbs. and must be installed using a U.L. listed outlet box approved for up to 75 lbs. or supported independently of the outlet box

SPECIFICATIONS

Rated Life	54000 Hours
Standards	ETL, cETL,Damp Location Listed
Input	120-277 VAC,50/60Hz
Dimming	ELV, 0-10V, TRIAC, WAC Home*
Color Temp	3000K
CRI	90
Construction	Steel frame with silica diffuser and natural alabaster shade

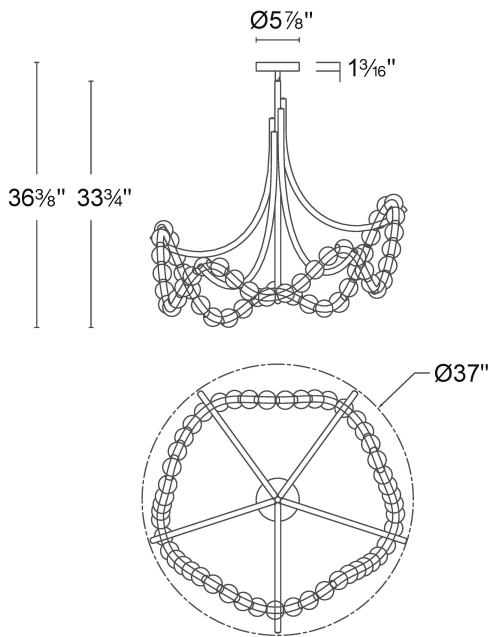

FM-50437

Model & Size	Color Temp	Finish	LED Watts	LED Lumens	Delivered Lumens
FM-50437 37"	3000K 3000K	AB Aged Brass AN Antique Nickel	34.2W 34.2W	3200 3200	1346 1346

Example: **FM-50437-AN**

For custom requests please contact customs@modernforms.com

* WAC Home components required for tunable white or Dim-to-Warm mode. See WAC Home section on website for additional information or use QR code on the right





Project: _____

Location: _____

Fixture Type: _____

Catalog Number: _____

AVAILABLE FINISHES:

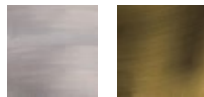

Parel

FM-50446

PRODUCT DESCRIPTION

Spanish Alabaster beads are strung on an LED loop and draped over gleaming arms. Dress up your ceiling with this delightful luminaire.

FEATURES

- Driver concealed within the canopy
- Sculptural frame illuminated by a fixed silica strand of First class quality Spanish alabaster orbs
- Natural alabaster with unique veining in each crafted piece
- NEC CODE (314.24) requires that ceiling outlet boxes in the U.S. support up to 50 lbs
- This fixture exceeds 50 lbs. and must be installed using a U.L. listed outlet box approved for up to 75 lbs. or supported independently of the outlet box

SPECIFICATIONS

Rated Life	54000 Hours
Standards	ETL, cETL,Damp Location Listed
Input	120-277 VAC,50/60Hz
Dimming	ELV, 0-10V, TRIAC, WAC Home*
Color Temp	3000K
CRI	90
Construction	Steel frame with silica diffuser and alabaster shades

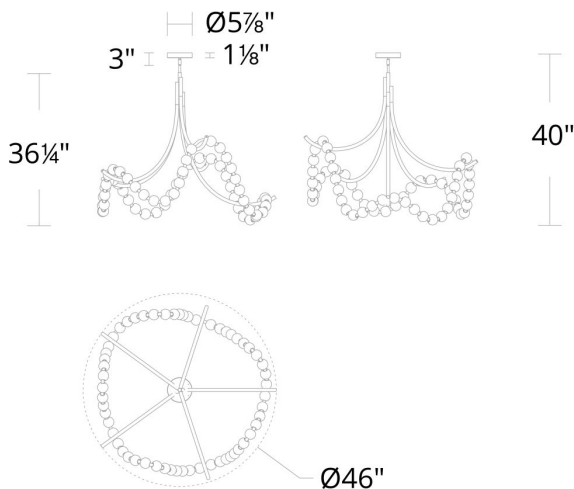

FM-50446

Model & Size	Color Temp	Finish	LED Watts	LED Lumens	Delivered Lumens
FM-50446 46"	3000K 3000K	AB Aged Brass AN Antique Nickel	40.9W 40.9W	4000 4000	2088 2088

Example: **FM-50446-AN**

For custom requests please contact customs@modernforms.com

* WAC Home components required for tunable white or Dim-to-Warm mode. See WAC Home section on website for additional information or use QR code on the right

